



---

**CERTIFICATE OF APPROVAL**  
**No CF 257**

---

This is to certify that, in accordance with  
CERTIFIRE's Rules for Certification  
The undermentioned products of

**CGI INTERNATIONAL LIMITED**

International House, Millfield Lane, Haydock, WA11 9GA  
Tel: 01942 710720 Fax: 01942 710730

Have been assessed against the requirements of the Technical Schedule(s)  
denoted below and are approved for use subject to the conditions  
appended hereto:

---

**CERTIFIED PRODUCT**

**'Pyroguard'**  
**Fire Resisting Glass**

**TECHNICAL SCHEDULE**

**TS 25 Fire Resistant Glass,  
Glazing Systems and Materials**

Signed and sealed for and on behalf of CERTIFIRE

A handwritten signature in black ink, appearing to read "Sir Ken Knight".

Sir Ken Knight  
Chairman - Management Council  
Page 1 of 25

Issued: 20<sup>th</sup> February 2006  
Revised: 5<sup>th</sup> February 2009  
Valid to: 19<sup>th</sup> February 2011



Only valid when authentic  
Seal is in place  
CERTIFIRE



**CERTIFICATE No CF 257**  
**CGI INTERNATIONAL LIMITED**

**Pyroguard Fire Resisting Glass**

This Certificate of Approval relates to the fire resistance of CGI International Limited 'Pyroguard' laminated glass products when used in the following applications, as defined in BS 476: Part 22: 1987 subject to the undermentioned conditions.

Glass Specification	Application	Fire Resistance Performance (mins)		Page No.
		Integrity	Insulation	
Pyroguard Clear/Wired 7 mm	Timber framed screens	30	0	4-7
Pyroguard Clear/Wired 7 mm	IGUs in timber framed screens	30	0	8
Pyroguard Clear/Wired 7 mm	Steel framed screens	30	0	9-10
Pyroguard Clear/Wired 7 mm	IGUs in steel framed screens	60	0	11
Pyroguard Clear/Wired 7 mm	Timber based doorsets	30	0	12-13
Pyroguard Clear/Wired 11 mm	Timber framed screens	30 & 60	0	14-16
Pyroguard Clear/Wired 11 mm	IGUs in timber framed screens	60	0	17
Pyroguard Clear/Wired 11 mm	Steel framed screens	60	0	18
Pyroguard Clear/Wired 11 mm	IGUs in steel framed screens	60	0	19
Pyroguard Clear/Wired 11 mm	Timber based doorsets	30	0	20
Pyroguard Clear/Wired 11 mm	Timber based doorsets	60	0	21
Pyroguard Clear/Wired 11 mm	Timber stile & rail doorsets	30	0	22-23
Pyroguard Clear/Wired 11 mm	IGUs/laminated in horizontal steel framed screens	30	0	24-25



---

**CERTIFICATE No CF 257**  
**CGI INTERNATIONAL LIMITED**

---

### **Pyroguard Fire Resisting Glass**

This product is approved on the basis of:

- a) Initial type testing
- b) A design appraisal against TS25
- c) Certification of quality management system to BS EN ISO 9001: 2000
- d) Inspection and surveillance of factory production control
- e) Audit Testing in accordance with TS25

This Certificate of Approval must be read in conjunction with CERTIFIRE Technical Schedule TS25, Fire Resistant Glass, Glazing Systems and Materials.

#### **General Requirements**

Where the glass is installed in a timber or steel framed screen, the orientation of the screen shall be no more than  $\pm 10^\circ$  from the vertical.

The edge cover to each pane shall be no less than 10 mm minimum.

#### **Options**

All systems may include decorative self adhesive leading or film on either or both faces or may be frosted or patterned on one face. Alternatively the glass may have a film applied to the known fire risk side only. If the fire risk may be from either side or it cannot be determined which side of the glass will be on the fire risk side, then films other than 3M – Ultra 400 clear and Llumar Window Film SCL SR PS4 shall not be applied.

Pyroguard glass may be bevelled or incorporate grooves subject to the minimum glass thickness being maintained i.e. by utilising thicker glass sheets bevelled at the edge or grooved to standard thickness.

**CERTIFICATE No CF 257**  
**CGI INTERNATIONAL LIMITED**

**Pyroguard 7 mm Clear/Wired glass in timber framed screens for periods of 30 minutes integrity**

For this application the following conditions shall apply:

The glass shall be glazed utilising the following basic specification:

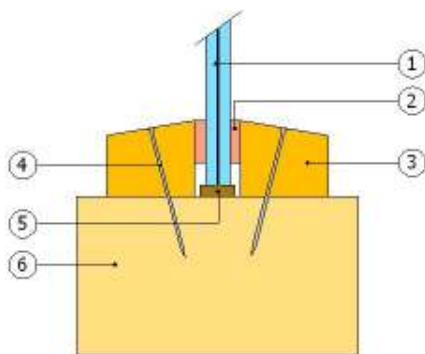

- ① Pyroguard 7 mm Clear or Wired
- ② 20 mm by 6 mm CGI 'K tape', ceramic fibre based glazing tape
- ③ 20 mm high by 40 mm wide square or chamfered (up to 30°) hardwood glazing beads, minimum density 660 kg/m<sup>3</sup>.
- ④ 38 mm long No. 8 steel screws at 200 mm centres (30° to glass)
- ⑤ Hardwood or Non-combustible setting blocks
- ⑥ 63 mm by 105 mm (minimum) hardwood framing sections, minimum density 530 kg/m<sup>3</sup>

This Certificate of Approval relates to the sizes of Pyroguard 7 mm Clear/Wired glass shown in Figure 1 below, when used in conjunction with the above system. The maximum permitted overall screen dimensions are 2220 mm wide by 2610 mm high.

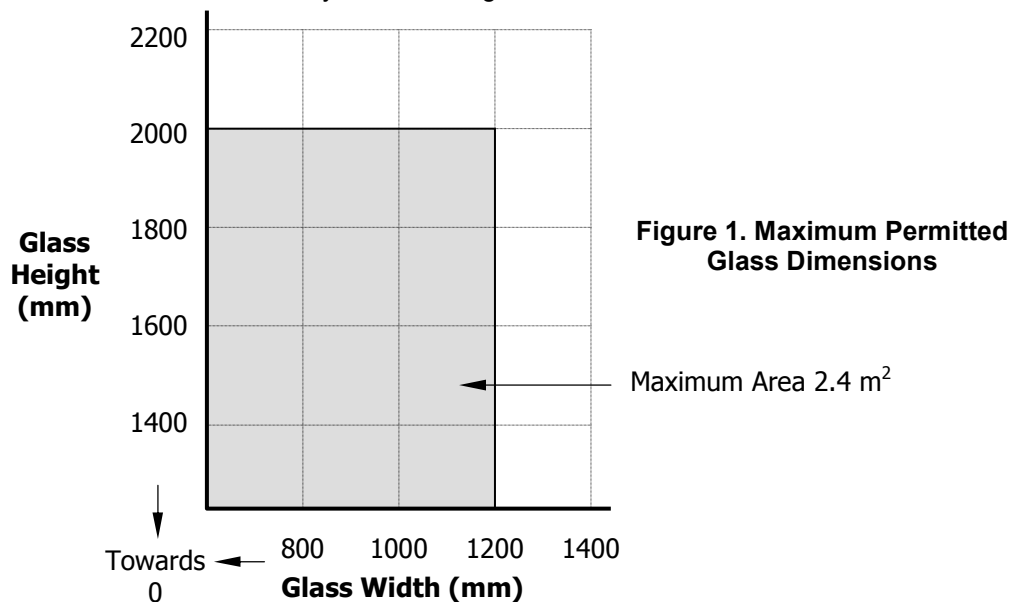

The aspect ratio of the glass may be unlimited within these aperture dimensions. Alternative glazing systems as detailed in Table 1 (Timber Doorsets) may be utilised subject to the dimensional limitations specified in Table 1. These systems may also be included in previously tested doorset fan and side-lights.

**CERTIFICATE No CF 257**  
**CGI INTERNATIONAL LIMITED**

**Pyroguard 7 mm Clear/Wired glass in timber framed screens for periods of 30 minutes integrity continued**

For this application the following conditions shall apply:

The glass shall be glazed utilising the following basic specification:

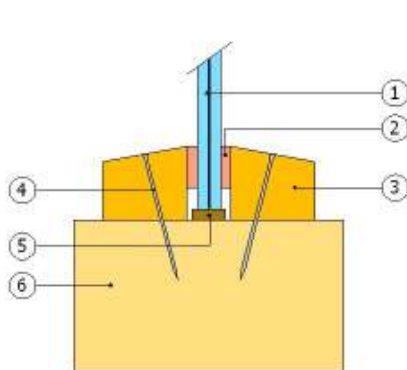

- ① Pyroguard 7 mm Clear or Wired
- ② 15 mm by 4 mm Pyroglaze P500 intumescent seal
- ③ 15 mm high by 15 mm wide square or chamfered (up to 30°) hardwood glazing beads, minimum density 530 kg/m<sup>3</sup>.
- ④ 30 mm long No. 8 steel screws at 200 mm centres (30° to glass)
- ⑤ Hardwood or Non-combustible setting blocks
- ⑥ 66 mm by 57 mm (minimum) hardwood framing sections, minimum density 530 kg/m<sup>3</sup>

This Certificate of Approval relates to the sizes of Pyroguard 7 mm Clear/Wired glass shown in Figure 2 below, when used in conjunction with the above system. The maximum permitted overall screen dimensions are 1900 mm wide by 2500 mm high.

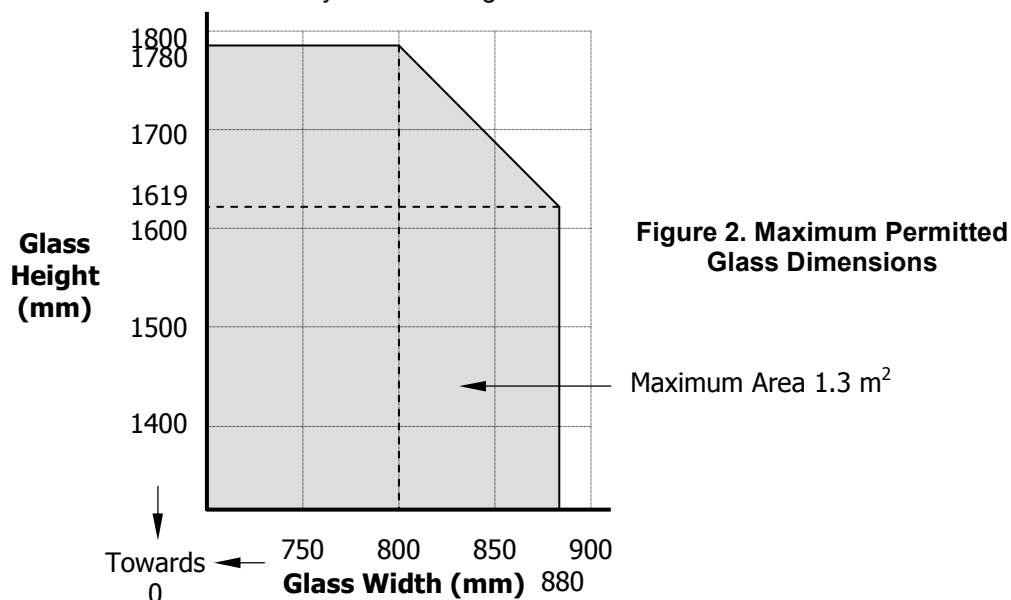

The aspect ratio of the glass may be unlimited within these aperture dimensions. Alternative glazing systems as detailed in Table 1 (Timber Doorsets) may be utilised subject to the dimensional limitations specified in Table 1. These systems may also be included in previously tested doorset fan and side-lights.

**CERTIFICATE No CF 257**  
**CGI INTERNATIONAL LIMITED**

**Pyroguard 7 mm Clear/Wired glass in single pane timber framed screens for periods of 30 minutes integrity**

For this application the following conditions shall apply:

The glass shall be glazed utilising the following basic specification:

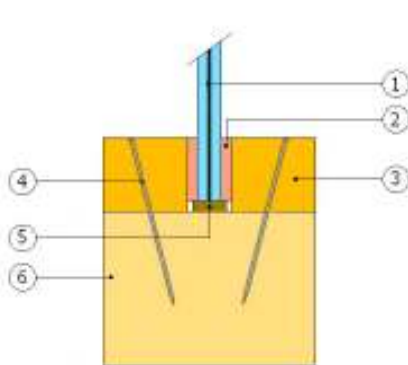

- ① Pyroguard 7 mm Clear or Wired
- ② Sealmaster Fireglaze (spacing achieved with 4 mm thick Kerafix pads)
- ③ 20 mm high by 31 mm wide square or chamfered (up to 30°) hardwood glazing beads, minimum density 640 kg/m<sup>3</sup>.
- ④ 50 mm long M4 steel screws at 200 mm centres (30° to glass)
- ⑤ Hardwood or Non-combustible setting blocks
- ⑥ 40 mm by 75 mm (minimum) hardwood framing sections, minimum density 640 kg/m<sup>3</sup>

This Certificate of Approval relates to the sizes of Pyroguard 7 mm Clear/Wired glass shown in Figure 3 below, when used in conjunction with the above system. The maximum permitted overall single pane screen dimensions are 1200 mm wide by 2200 mm high.

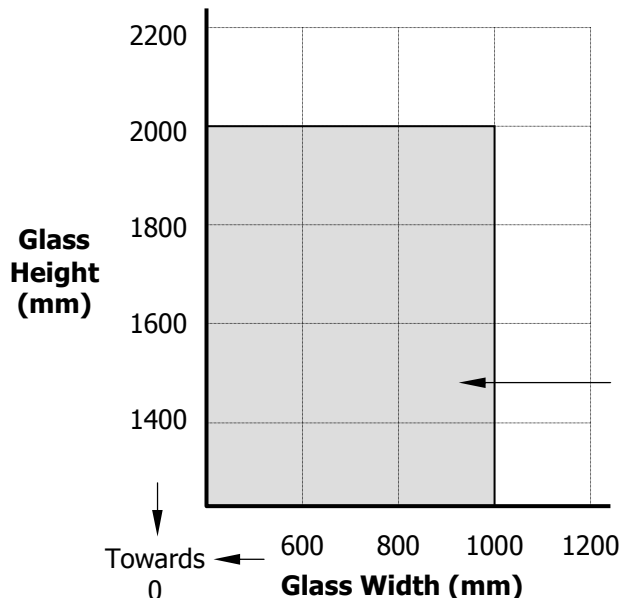

**Figure 3. Maximum Permitted Glass Dimensions**

The aspect ratio of the glass may be unlimited within these aperture dimensions. Alternative glazing systems as detailed in Table 1 (Timber Doorsets) may be utilised subject to the dimensional limitations specified in Table 1. These systems may also be included in previously tested doorset fan and side-lights.

**CERTIFICATE No CF 257**  
**CGI INTERNATIONAL LIMITED**

**Pyroguard 7 mm Clear/Wired glass in single pane softwood framed screens for periods of 30 minutes integrity**

For this application the following conditions shall apply:

The glass shall be glazed utilising the following basic specification:

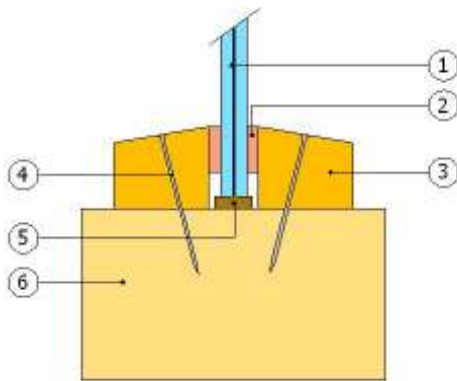

- ① Pyroguard 7 mm Clear or Wired
- ② 20 mm by 3 mm CGI 'K tape', ceramic fibre based glazing tape
- ③ 25 mm high by 40 mm wide square or chamfered (up to 30°) hardwood glazing beads, minimum density 650 kg/m<sup>3</sup>.
- ④ 50 mm long M4 steel screws at 200 mm centres (30° to glass)
- ⑤ Hardwood or Non-combustible setting blocks
- ⑥ 92 mm by 45 mm (minimum) softwood framing sections, minimum density 450 kg/m<sup>3</sup>

This Certificate of Approval relates to the sizes of Pyroguard 7 mm Clear/Wired glass shown in Figure 4 below, when used in conjunction with the above system. The maximum permitted overall screen dimensions are 2506 mm wide and 2706 mm high.

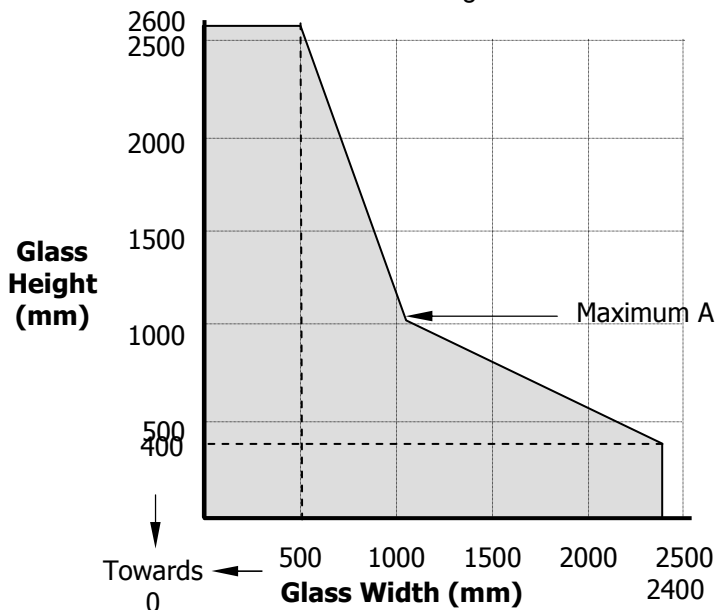

**Figure 4. Maximum Permitted Glass Dimensions**





**CERTIFICATE No CF 257**  
**CGI INTERNATIONAL LIMITED**

**Pyroguard 7 mm Clear/Wired 'Insulated Glazed Units' glass in timber framed screens for periods of 30 minutes integrity**

For this application the following conditions shall apply:

The 'IGU' shall comprise a single layer of Pyroguard 7 mm glass, a 12 mm Argon filled cavity with steel spacer bars and a single layer of 4 mm annealed glass (including 'low E' coated glasses), to form a 23 mm thick unit. The panes must be oriented such that the 4 mm layer faces the fire risk direction.

The glass shall be installed in an identical manner to 'Pyroguard 7 mm' as shown on Page 4.

**Maximum Permitted Pane Dimensions**

This Certificate of Approval relates to the sizes of Pyroguard 7 mm Clear/Wired glass IGUs shown in Figure 5 below, when used in conjunction with the above system. The glass may be installed within single-paned screens. The aspect ratio of the glass may be unlimited within these aperture dimensions.

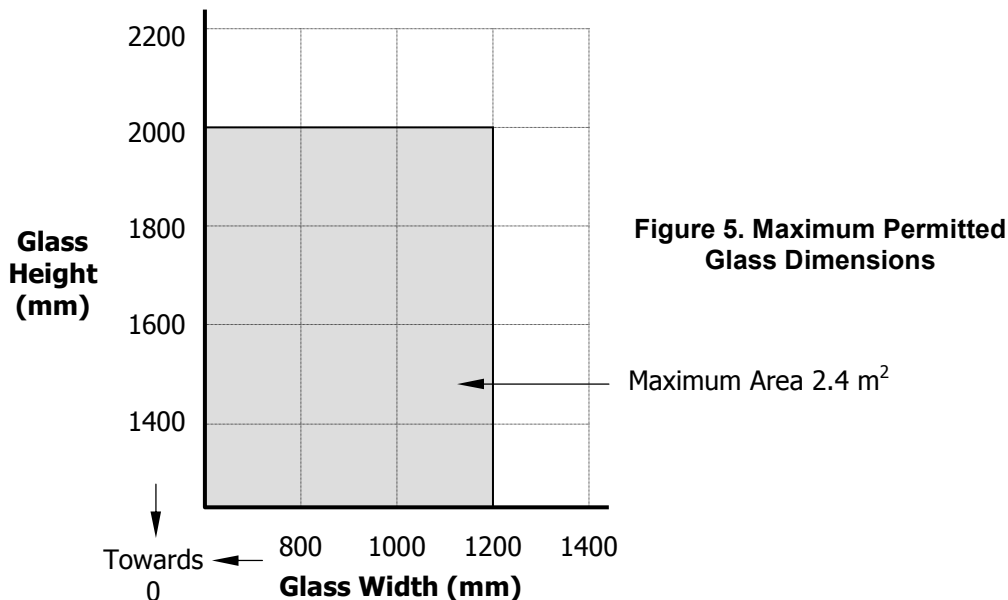

**CERTIFICATE No CF 257**  
**CGI INTERNATIONAL LIMITED**

**Pyroguard 7 mm Clear/Wired glass in steel framed screens for periods of 30 minutes integrity**

For this application the following conditions shall apply:

The glass shall be installed into a previously tested or CERTIFIRE approved framing system (which is covered appropriately by test or assessment evidence) using pressure plate glazing, screw-fixed or clip-on retaining beads, see examples below. The glass shall be glazed into the screen with CGI 'K Tape' ceramic fibre gasket on both faces and set on non-combustible setting blocks to determine the correct edge cover.

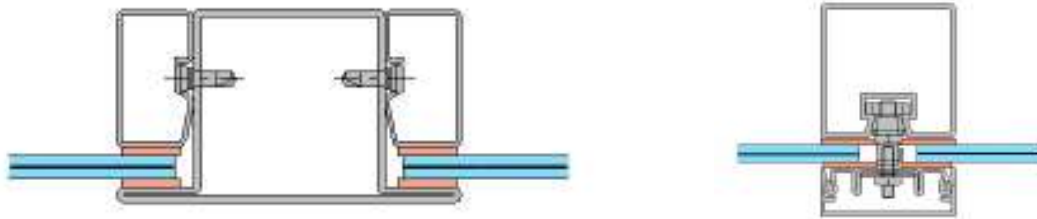

**Maximum Permitted Pane Dimensions**

This Certificate of Approval relates to the sizes of Pyroguard 7 mm Clear/Wired glass shown in Figure 6 below, when used in conjunction with the above system. The maximum permitted overall screen dimensions are 2090 mm high by 2530 mm wide. The aspect ratio of the glass may be unlimited within these aperture dimensions. Maximum Area 1.62 m<sup>2</sup> (single-pane panels)

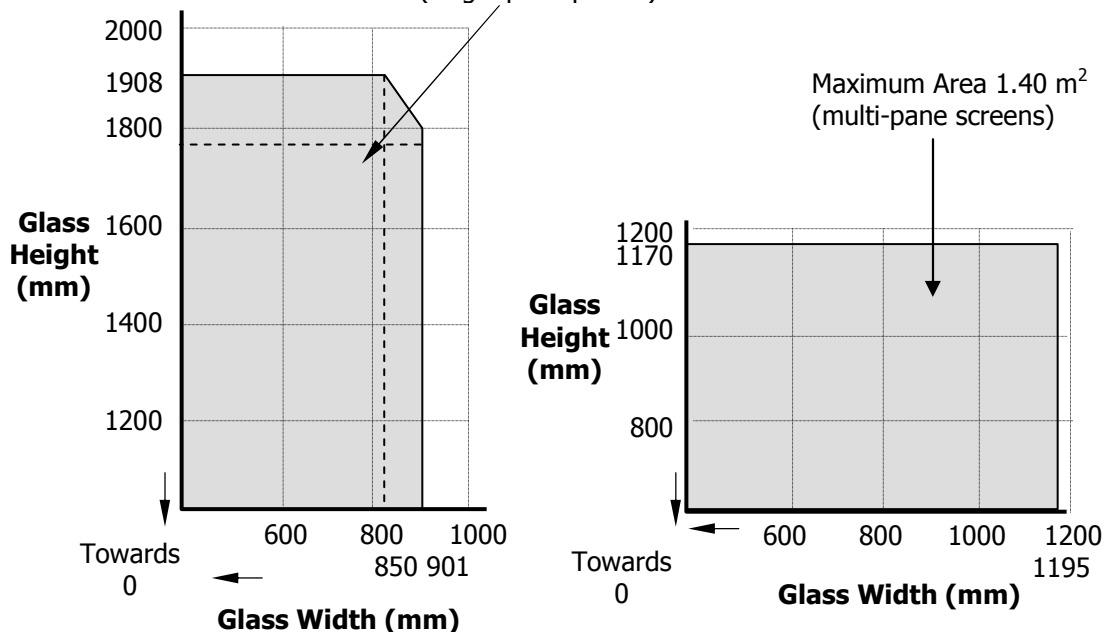

**Figure 6. Maximum Permitted Glass Dimensions**





---

**CERTIFICATE No CF 257**  
**CGI INTERNATIONAL LIMITED**

---

**Pyroguard 7 mm Clear/Wired glass in steel framed screens for periods of 30 minutes integrity (continued)**

The aspect ratio of the glass may be unlimited within these aperture dimensions.

The glass in the above stated sizes may be made into Double Glazed Units/Insulated glazed units to provide 30 minutes integrity. The unit shall comprise one pane of 7 mm Pyroguard Clear glass and the other of either 6 mm tempered glass or 6 mm annealed float glass (including Low E glass). The 7 mm Pyroguard Clear glass face shall be orientated towards the fire risk side.

Double glazed units may only be provided in single pane assemblies, i.e. multi-pane glazed screens may not be glazed with double glazed units.

A handwritten signature in black ink, appearing to be "K. M. ...".

**CERTIFICATE No CF 257**  
**CGI INTERNATIONAL LIMITED**

**Pyroguard 7 mm Clear/Wired 'Insulated Glazed Units' glass in steel framed screens for periods of 60 minutes integrity**

For this application the following conditions shall apply:

The 'IGU' shall comprise a single layer of Pyroguard 7 mm glass, a 12 mm Argon filled cavity with steel spacer bars and a single layer of 4 mm toughened glass 'including 'low E' glasses), to form a 23 mm thick unit. The panes must be oriented such that the Pyroguard 7 mm glass faces the fire risk direction.

The glass shall be installed into a previously tested or CERTIFIRE approved framing system (which is covered appropriately by test or assessment evidence) using pressure plate glazing, screw-fixed or clip-on retaining beads. The glass shall be glazed into the screen with 'K Tape' ceramic fibre gasket on both faces and set on hardwood or non-combustible setting blocks to determine the correct edge cover.

**Maximum Permitted Pane Dimensions**

This Certificate of Approval relates to the sizes of Pyroguard 7 mm Clear/Wired glass IGUs shown in Figure 7 below, when used in conjunction with the above system. The glass may be installed within multi-paned screens providing that the overall height of the screen does not exceed 3000 mm. The aspect ratio of the glass may be unlimited within these aperture dimensions.

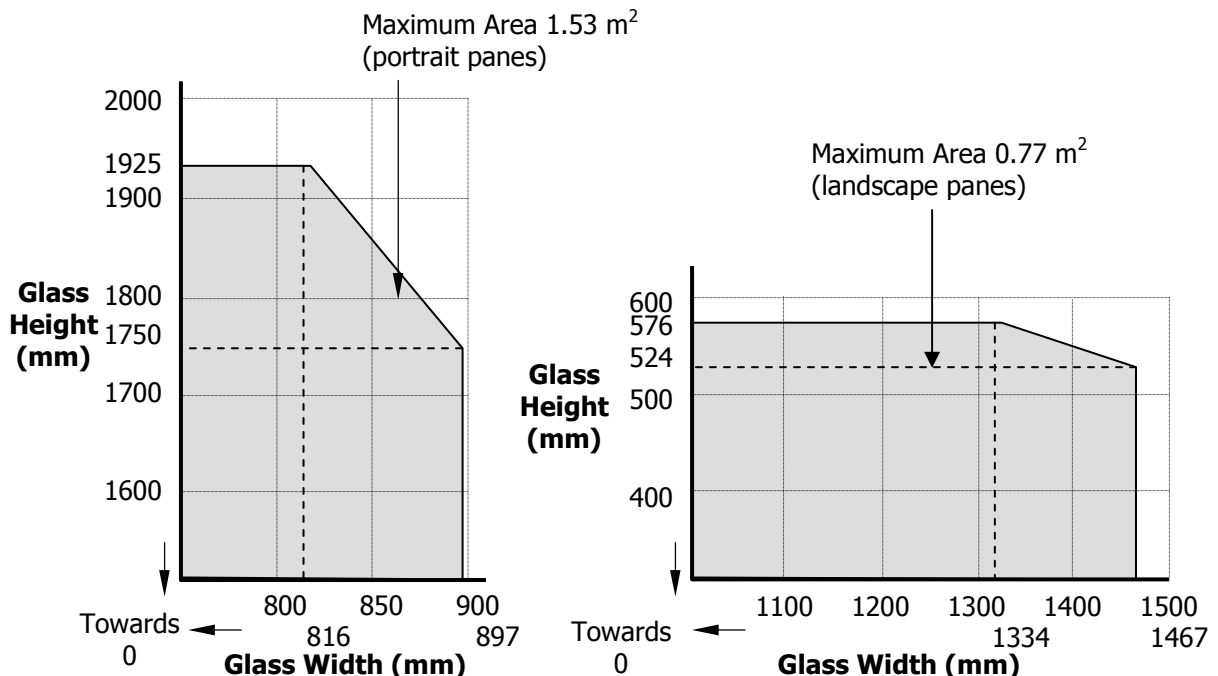

**Figure 7. Maximum Permitted Glass Dimensions**



**CERTIFICATE No CF 257**  
**CGI INTERNATIONAL LIMITED**

**Pyroguard 7 mm Clear/Wired glass (including IGUs) in timber based doorsets for periods of 30 minutes integrity**

For this application the following conditions shall apply:

The glass shall be glazed within a previously fire tested or CERTIFIRE approved timber based doorset utilising the following basic specification:

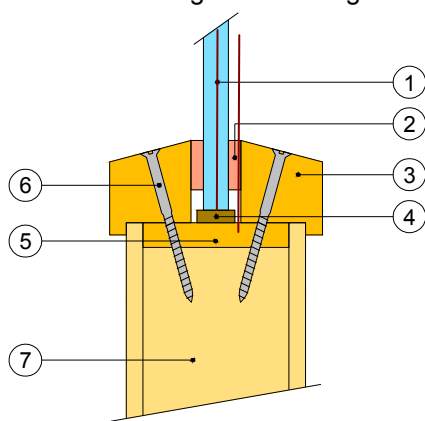

- ① Pyroguard 7 mm Clear or Wired Glass\*
- ② Glazing system (see below)
- ③ Hardwood glazing beads (see below)
- ④ Non-combustible/hardwood setting blocks
- ⑤ Liner (see below)
- ⑥ Fixings (see below)
- ⑦ Nominally 44 mm thick FD30 door leaf

\* Option of IGU of Pyroguard 7 mm clear or wired glass, 6 mm steel spacer and 6 mm toughened glass, with the system specified in Table 1.

The doorset shall be CERTIFIRE approved or have test evidence for the inclusion of apertures of the proposed dimensions.

This Certificate of Approval relates to the sizes of Pyroguard 7 mm Clear/Wired glass shown in the Table 1 below, when used in conjunction with the above system. The aspect ratio of the glass may be unlimited within these aperture dimensions.

**Table 1**

Glazing System	Maximum Pane dimension – height (mm)	Maximum Pane dimension – width (mm)	Maximum Pane Area (m <sup>2</sup> )
Hodgsons Sealants Firestrip 30 <sup>(1)</sup>	875	610	0.53
Lorient Flexible Figure 1 glazing system <sup>(2)</sup>	1236 (at 574 w)	610 (at 1163 h)	0.71
Lorient System 36/7 <sup>(3)</sup>	875	610	0.58
Pyroplex 8193 glazing system <sup>(4)</sup>	600	610	0.36
Pyroplex 30049 glazing system <sup>(5)</sup>	750	610	0.46
Pyroplex 30054 glazing system <sup>(6)</sup>	750	610	0.46
Pyroplex 8492 glazing system <sup>(7)</sup>	403	610	0.25
Sealmaster Therm-A-Strip 10 mm x 2 mm <sup>(8)</sup>	2125 (at 300 w)	610 (at 1049 h)	0.64
Sealmaster G30 glazing gasket between beads and glass <sup>(8)</sup>	2125 (at 300 w)	610 (at 1049 h)	0.64
Sealmaster G30 glazing gasket in CGI Ltd bead system <sup>(9)</sup>	800	610	0.49
IGU + Therm-A-Strip 10 x 2 mm <sup>(10)</sup>	1210	610	0.74
The aspect ratio of the glass may be unlimited within these pane dimensions or area			





**CERTIFICATE No CF 257**  
**CGI INTERNATIONAL LIMITED**

**Pyroguard 7 mm Clear/Wired glass in timber based doorsets for periods of 30 minutes integrity**

(1)	The glazing beads shall be of Sapele, or equivalent or higher density (610 kg/m <sup>3</sup> ), sections, 22mm wide by 21mm high, chamfered by approximately 13° and fixed using 1.5 mm diameter, 50mm long steel pins at a maximum of 100mm centres and angled to pass under the face of the glass.
(2)	The glazing beads shall be hardwood of minimum density 550 kg/m <sup>3</sup> or MDF of minimum 750 kg/m <sup>3</sup> density, sections, 22mm wide by 15 mm high with a 5 mm by 5 mm bolection return, chamfered by approximately 15° and fixed using 1.5 mm diameter, 40mm long steel pins or screws at a maximum of 150mm centres and angled to pass under the face of the glass. A secondary hardwood liner (integral or separate) or a LX4402 intumescent liner shall be used to line apertures cut within flaxboard substrates.
(3)	The glazing beads shall be of minimum density 550 kg/m <sup>3</sup> , sections, 22mm wide by 13 mm high, chamfered by approximately 15° and fixed using 1.5mm diameter, 40mm long steel pins or screws at a maximum of 200mm centres and angled to pass under the face of the glass. A secondary Palusol based intumescent material is required to be used as a lining around the perimeter of apertures cut within flaxboard substrates which have a density below 500 kg/m <sup>3</sup> .
(4)	The glazing beads shall be of minimum density 630 kg/m <sup>3</sup> , sections, 20mm wide by 14.5 mm high with a 5 mm by 5 mm bolection return, chamfered by approximately 20° and fixed using, 50 mm long steel screws at a maximum of 150mm centres and angled at 30-45°. A secondary 6 mm thick hardwood liner (min. density 630 kg/m <sup>3</sup> ) shall be used to line apertures cut within all substrates.
(5)	The glazing beads shall be of minimum density 630 kg/m <sup>3</sup> , sections, 20mm wide by 14.5 mm high with a 5 mm by 5 mm bolection return, chamfered by approximately 20° and fixed using, 36 mm long steel screws at a maximum of 150mm centres and angled at 30-45°. A secondary 6 mm thick hardwood liner (min. density 630 kg/m <sup>3</sup> ) shall be used to line apertures cut within all substrates.
(6)	The glazing beads shall be of minimum density 630 kg/m <sup>3</sup> , sections, 20mm wide by 14.5 mm high with a 5 mm by 5 mm bolection return, chamfered by approximately 20° and fixed using, 50 mm long steel screws at a maximum of 150mm centres and angled at 30-45°. A secondary 6 mm thick hardwood liner (min. density 630 kg/m <sup>3</sup> ) shall be used to line apertures cut within all substrates.
(7)	The glazing beads shall be of minimum density 630 kg/m <sup>3</sup> , sections, 20 mm wide by 14.5 mm high with a 5 mm by 5 mm bolection return, chamfered by approximately 20° and fixed using, 45 mm long steel screws at a maximum of 150mm centres and angled at 30-45°.
(8)	The glazing beads shall be hardwood of minimum density 500 kg/m <sup>3</sup> , sections, 25 mm wide by 23 mm high with a 5 mm by 5 mm bolection return, chamfered by approximately 15° and fixed using, 38 mm long steel pins or screws at a maximum of 150mm vertical and 100 mm horizontal centres and angled at 15°. A secondary 6 mm thick hardwood liner (min. density 500 kg/m <sup>3</sup> ) shall be used to line apertures cut within all substrates.
(9)	Asymmetrical beading system as shown in CGI International Ltd Drawing no. G20011-01 (01/07/04)
(10)	The glazing beads shall be hardwood of minimum density 650 kg/m <sup>3</sup> , sections, 16.5 mm wide by 25 mm high with a 5 mm by 5 mm bolection return, chamfered by approximately 15° and fixed using, 40 mm long steel pins or screws at a maximum of 150mm centres and angled at 30°. A secondary 6 mm thick hardwood liner (min. density 500 kg/m <sup>3</sup> ) shall be used to line apertures cut within all substrates.

These systems may also be included in previously tested doorset fan and side-lights.

## CERTIFICATE No CF 257

### CGI INTERNATIONAL LIMITED

**Pyroguard 11 mm glass in timber framed screens for periods of 30 & 60 minutes integrity (System 1)**

For this application the following conditions shall apply:

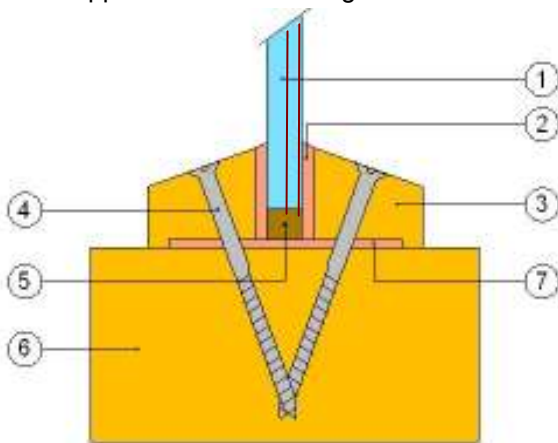

- ① Pyroguard 11 mm Clear or Wired
- ② Sealmaster Fireglaze Compound (approx. 23 mm by 4 mm)
- ③ 25 mm high by 37 mm wide square or chamfered (up to 30°) hardwood glazing beads, minimum density 650 kg/m<sup>3</sup>.
- ④ 50 mm long No. 8 steel screws at 200 mm centres (approx. 30° to glass)
- ⑤ Hardwood or Non-combustible setting blocks
- ⑥ 92 mm by 45 mm (minimum) hardwood framing sections, minimum density 650 kg/m<sup>3</sup>
- ⑦ 45 mm wide by 2 mm thick Sealmaster 'GL60' intumescent liner

This Certificate of Approval relates to the sizes of Pyroguard 11 mm glass shown in Figure 8 below, when used in conjunction with the above system. The aspect ratio of the glass may be unlimited within these aperture dimensions.

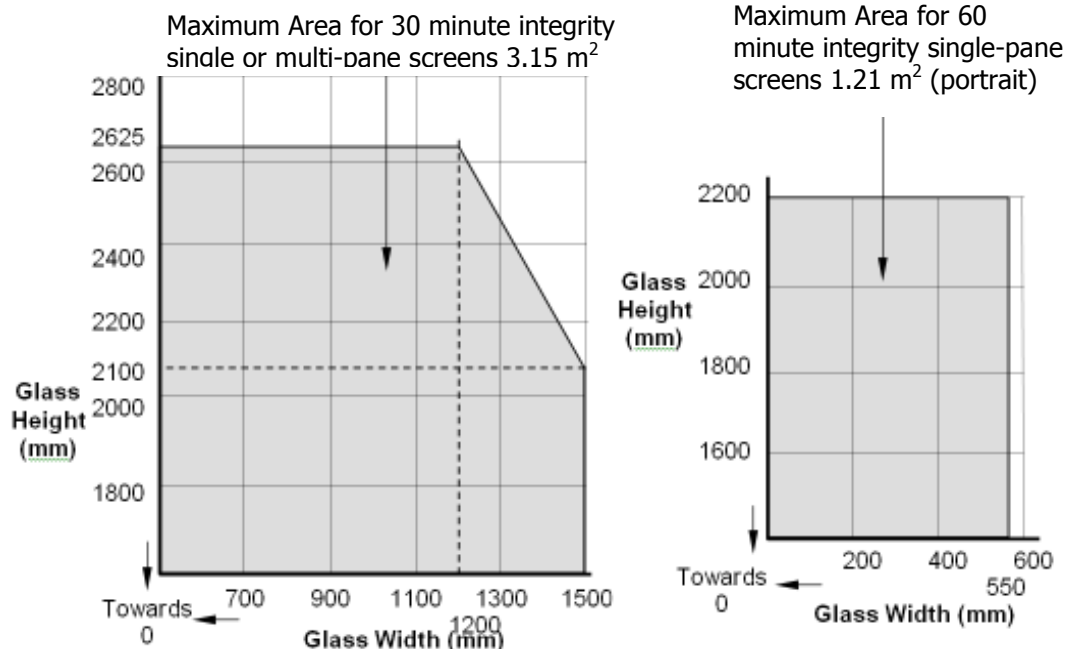

**Figure 8. Maximum Permitted Glass Dimensions**

These systems may also be included in previously tested doorset fan and side-lights.

**CERTIFICATE No CF 257**  
**CGI INTERNATIONAL LIMITED**

**Pyroguard 11 mm glass in timber framed screens for periods of 30 & 60 minutes integrity (System 2) continued**

For this application the following conditions shall apply:

The glass shall be glazed utilising the following basic specification:

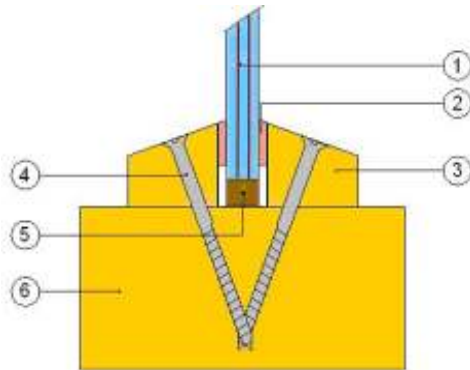

- ① Pyroguard 11 mm Clear or Wired
- ② Palusol 10 mm by 2 mm
- ③ 22 mm high by 20 mm wide square or chamfered (up to 30°) hardwood glazing beads, minimum density 660 kg/m<sup>3</sup>.
- ④ 38 mm long No. 8 steel screws at 200 mm centres (approx. 30° to glass)
- ⑤ Hardwood or Non-combustible setting blocks
- ⑥ 92 mm by 45 mm (minimum) hardwood framing sections, minimum density 650 kg/m<sup>3</sup>

This Certificate of Approval relates to the sizes of Pyroguard 11 mm glass shown in Figure 9 below, when used in conjunction with the above system. The aspect ratio of the glass may be unlimited within these aperture dimensions.

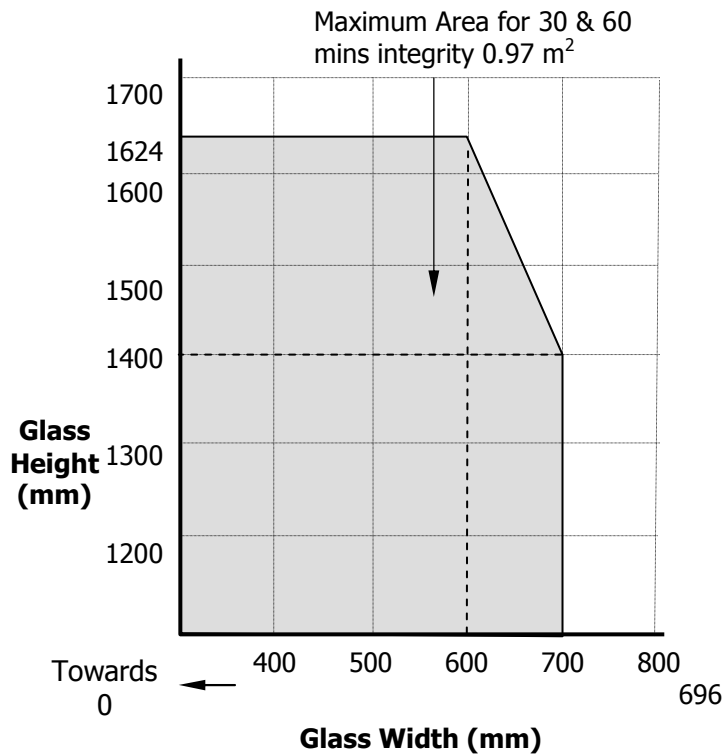

**Figure 9. Maximum Permitted Glass Dimensions**

These systems may also be included in previously tested doorset fan and side-lights.

**CERTIFICATE No CF 257**  
**CGI INTERNATIONAL LIMITED**

**Pyroguard 11 mm Clear/Wired glass in multi-pane timber framed screens for periods of 30 minutes integrity**

For this application the following conditions shall apply:

The glass shall be glazed utilising the following basic specification:

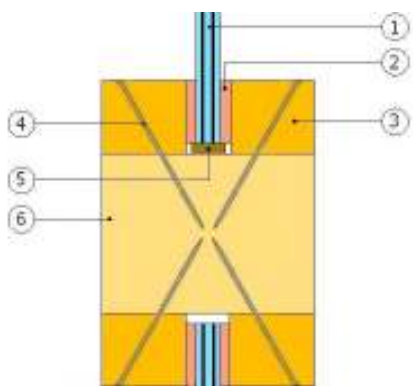

- ① Pyroguard 11 mm Clear or Wired
- ② 16 mm by 6 mm CGI 'K tape', ceramic fibre based glazing tape
- ③ 20 mm high by 36.5 mm wide square or chamfered (up to 30°) hardwood glazing beads, minimum density 640 kg/m<sup>3</sup>.
- ④ 50 mm long M4 steel screws at 200 mm centres (45° to glass)
- ⑤ Hardwood or Non-combustible setting blocks
- ⑥ 45 mm by 92 mm (minimum) hardwood framing sections, minimum density 640 kg/m<sup>3</sup>

This Certificate of Approval relates to the sizes of Pyroguard 11 mm Clear/Wired glass shown in Figure 10 below, when used in conjunction with the above system. The maximum permitted overall screen height is 3000 mm.

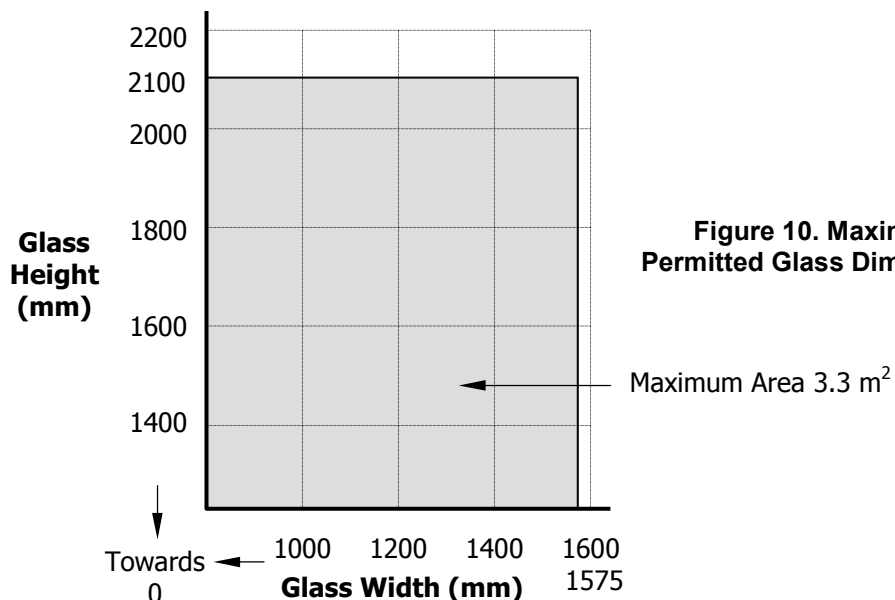

**CERTIFICATE No CF 257**  
**CGI INTERNATIONAL LIMITED**

**Pyroguard 11mm IGUs in single pane timber framed screens for periods of 60 minutes integrity**

For this application the following conditions shall apply:

The glass shall be glazed utilising the following basic specification:

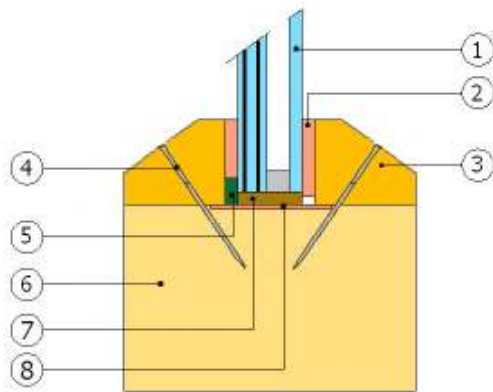

- ① IGU of Pyroguard 11 mm Clear or Wired Glass, 12mm steel spacer and 4 mm float glass
- ② 20 & 15 mm by 6 mm CGI 'K tape', ceramic fibre based glazing tape
- ③ 25 mm high by 28.5 mm wide chamfered (30°) hardwood glazing beads, minimum density 650 kg/m<sup>3</sup>.
- ④ 50 mm long M4 steel screws at 200 mm centres (approx. 30° to glass)
- ⑤ CXL high temperature adhesive
- ⑥ 92 mm by 45 mm (minimum) hardwood framing sections, minimum density 650 kg/m<sup>3</sup>
- ⑦ Sealmaster Fireglaze compound with Hardwood or Non-combustible setting blocks
- ⑧ Sealmaster GL60 Liner

This Certificate of Approval relates to the sizes of Pyroguard 11 mm glass shown in Figure 11 below, when used in conjunction with the above system. The aspect ratio of the glass may be unlimited within these aperture dimensions.

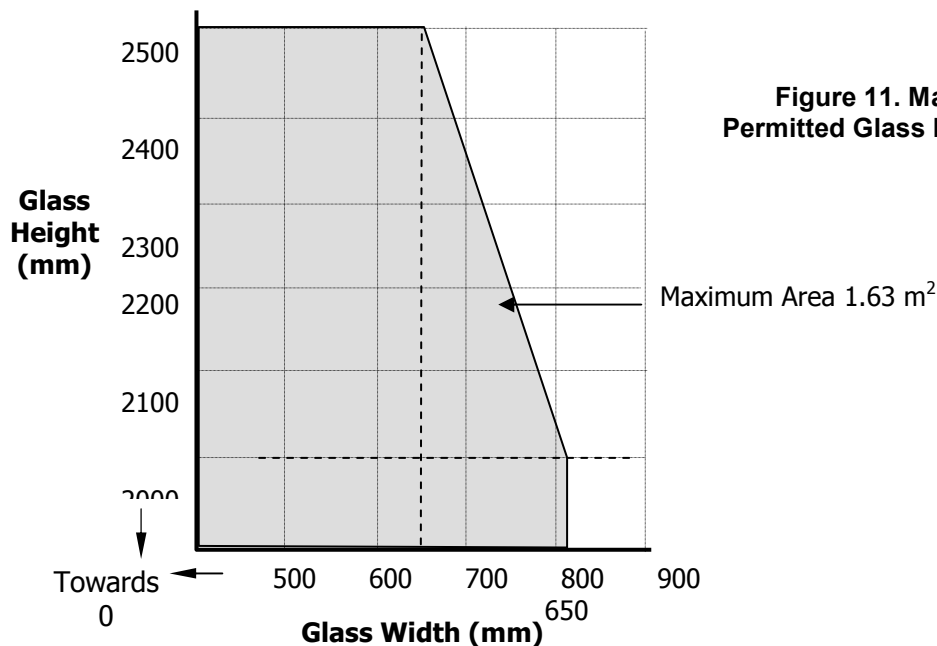



**CERTIFICATE No CF 257**  
**CGI INTERNATIONAL LIMITED**

**Pyroguard 11 mm glass in steel framed screens for periods of 60 minutes integrity**

For this application the following conditions shall apply:

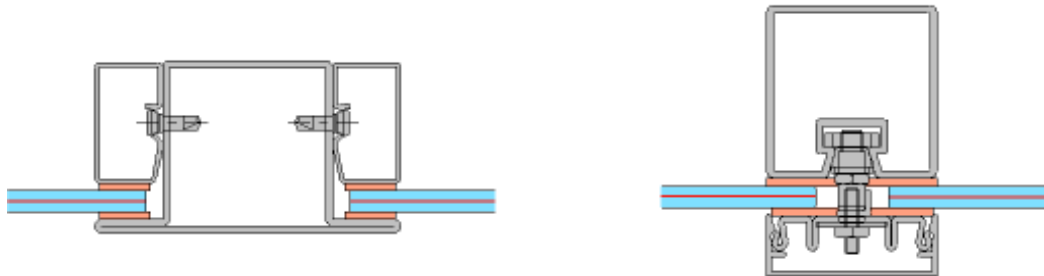
The glass shall be installed into a previously tested or CERTIFIRE approved framing system (which is covered appropriately by test or assessment evidence) using pressure plate glazing, screw-fixed or clip-on retaining beads, see examples below. The glass shall be glazed into the screen as described in the table below and set on non-combustible setting blocks to determine the correct edge cover.



System	Glazing Material	Single/Multi-Pane
1	20 x 4 mm Mann McGowan P500 intumescent strips to both faces of glass	Single Pane
2	'K' tape ceramic gasket to both faces of glass	Multi-Pane (maximum overall screen size of 2150 mm high by 2550 mm wide)

**Maximum Permitted Pane Dimensions**

This Certificate of Approval relates to the sizes of Pyroguard 11 mm glass shown in Figure 12 below, when used in conjunction with the above system. The aspect ratio of the glass may be unlimited within these aperture dimensions

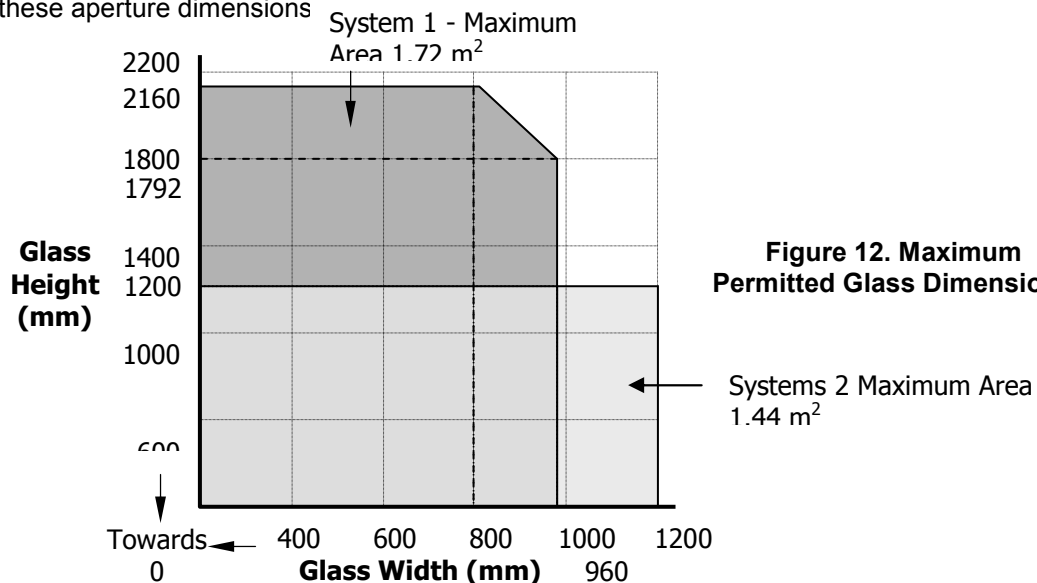
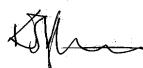

**CERTIFICATE No CF 257**  
**CGI INTERNATIONAL LIMITED**

**Pyroguard 11 mm 'Insulated Glazed Units' glass in steel framed screens for periods of 60 minutes integrity**

For this application the following conditions shall apply:

The 'IGU' shall comprise a single layer of Pyroguard 11 mm glass, a 10-12 mm cavity with steel spacer bars and a single layer of 4-6 mm toughened or float glass, to form a 25-29 mm thick unit. The panes must be oriented such that the Pyroguard 11 mm layer faces the fire risk direction.

The glass shall be installed into a previously tested or CERTIFIRE approved framing system (which is covered appropriately by test or assessment evidence) using pressure plate glazing, screw-fixed or clip-on retaining beads. The glass shall be glazed into the screen with 'K tape' ceramic fibre gasket on both faces, bonded with a ceramic based adhesive across the top edge (between tape/frame and tape/glass) and set on hardwood or non-combustible setting blocks to determine the correct edge cover.

**Maximum Permitted Pane Dimensions**

This Certificate of Approval relates to the sizes of Pyroguard 11 mm glass IGUs shown in Figure 13 below, when used in conjunction with the above system. The glass may only be installed within single paned screens. The aspect ratio of the glass may be unlimited within these aperture dimensions.

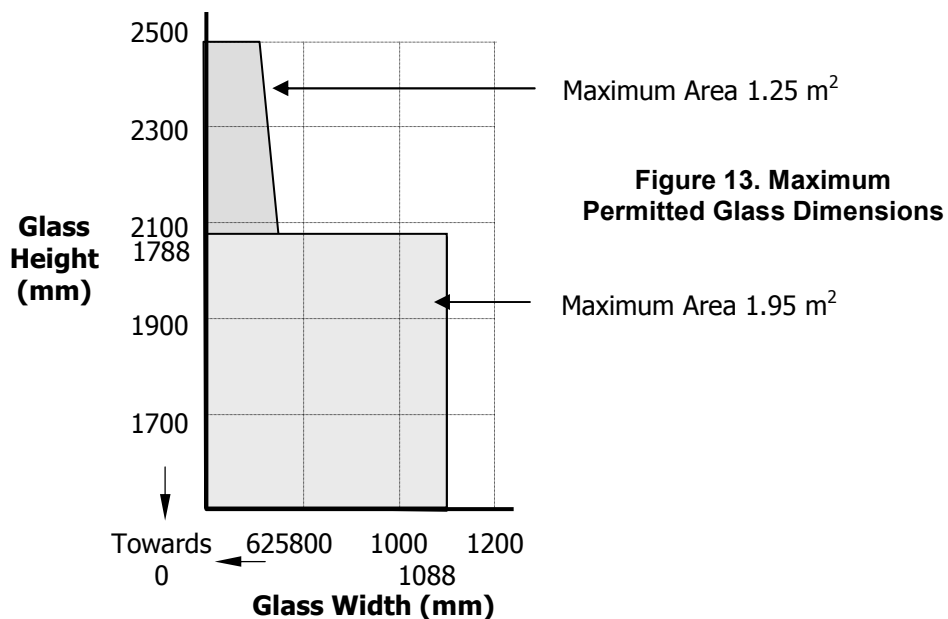

**CERTIFICATE No CF 257**  
**CGI INTERNATIONAL LIMITED**

**Pyroguard 11 mm glass in timber based doorsets for periods of 30 minutes integrity**

For this application the following conditions shall apply:

The glass shall be glazed within a previously fire tested or CERTIFIRE approved timber based doorset utilising the following basic specification:

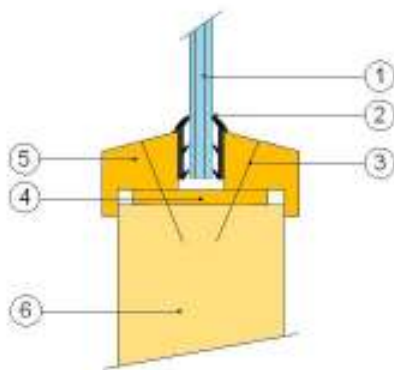

- ① Pyroguard 11 mm Glass
- ② Lorient Flexible Figure 1 glazing gasket
- ③ 40 mm long steel screws at a maximum of 150mm centres and angled at 45°
- ④ Hardwood liner 38 x 6 mm
- ⑤ Hardwood or MDF glazing beads 25 mm by 20 mm including a 10 mm by 6 mm bolection return chamfered at 30° and minimum 650 k/m<sup>3</sup> density HW or 750 kg/m<sup>3</sup> MDF
- ⑥ Nominally 44 mm thick FD60 door leaf

The doorset shall be CERTIFIRE approved or have test evidence for the inclusion of apertures of the proposed dimensions.

This Certificate of Approval relates to the sizes of Pyroguard 11 mm Clear/Wired glass shown in Figure 14 below, when used in conjunction with the above system. The aspect ratio of the glass may be unlimited within these aperture dimensions.

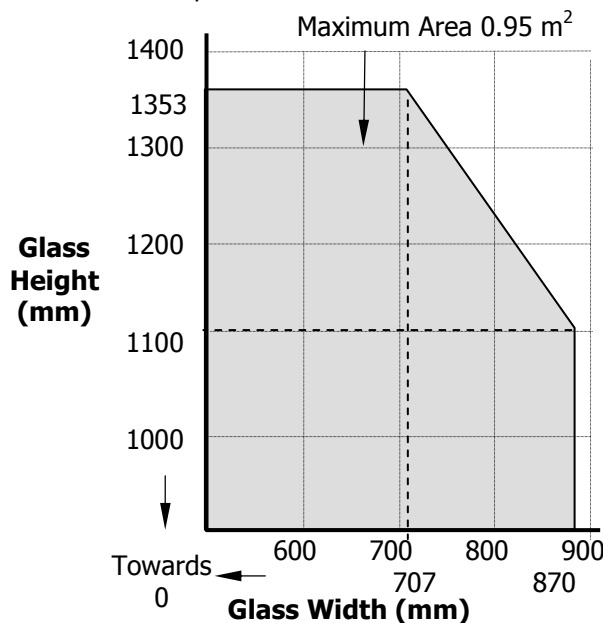

**Figure 14. Maximum Permitted Glass Dimensions**

These systems may also be included in previously tested doorset fan and side-lights.

**CERTIFICATE No CF 257**  
**CGI INTERNATIONAL LIMITED**

**Pyroguard 11 mm glass in timber based doorsets for periods of 60 minutes integrity**

For this application the following conditions shall apply:

The glass shall be glazed within a previously fire tested or CERTIFIRE approved timber based doorset utilising the following basic specification:

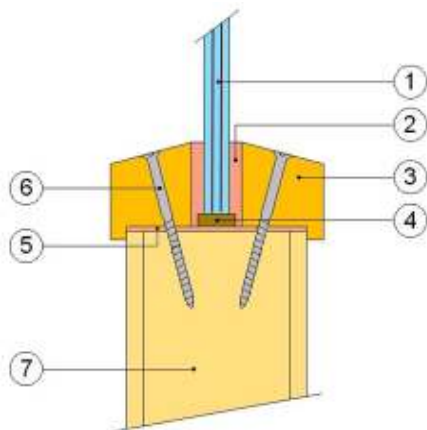

- ① Pyroguard 11 mm Glass
- ② Sealmaster FireGlaze approx. 4 mm thick
- ③ Hardwood glazing beads 28 mm by 27.5 mm including a 5 mm by 5 mm bolection return chamfered at 30° and minimum 650 k/m<sup>3</sup> density
- ④ Non-combustible or hardwood setting blocks
- ⑤ Sealmaster GL60 Liner
- ⑥ 38 mm long steel screws at a maximum of 150mm vertical and 100 mm horizontal centres and angled at 15°
- ⑦ Nominally 54 mm thick FD60 door leaf

The doorset shall be CERTIFIRE approved or have test evidence for the inclusion of apertures of the proposed dimensions.

This Certificate of Approval relates to the sizes of Pyroguard 11 mm Clear/Wired glass shown in Figure 15 below, when used in conjunction with the above system. The aspect ratio of the glass may be unlimited within these aperture dimensions.

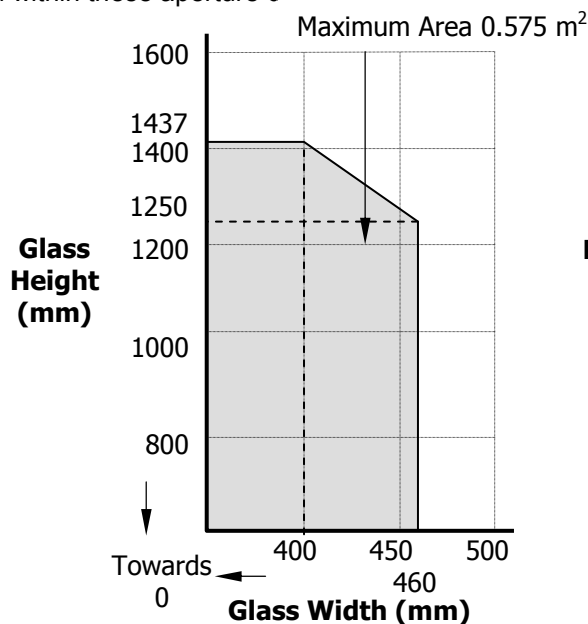

**Figure 15. Maximum Permitted Glass Dimensions**

These systems may also be included in previously tested doorset fan and side-lights.

**CERTIFICATE No CF 257**  
**CGI INTERNATIONAL LIMITED**

**Pyroguard 11 mm glass in timber stile and rail doorsets for periods of 30 minutes integrity**

The doorsets may be single-acting, single -leaf only, with an engaged latching device and are to be as detailed within the figures below:

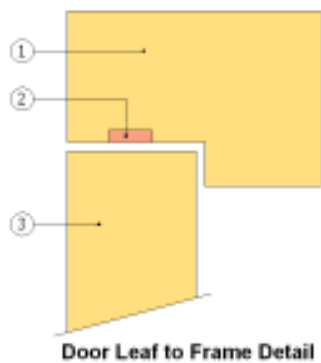

- ① 67 mm by 57 mm softwood or hardwood door frame with 19 mm integral stop, minimum density 450 kg/m<sup>3</sup>
- ② Lorient Polyproducts Ltd LP1504 15 x 4mm intumescent seals, positioned centrally within the reveal of the frame, at the head and vertical edges. The leaf to frame gap must not exceed 4 mm.
- ③ Minimum 100 mm by 44 mm hardwood stiles and rails (bottom rail 200 mm minimum) minimum density 640 kg/m<sup>3</sup>. Stiles and rails must be mortice & tenon jointed

The door leaves may be provided with a mid-rail (or a number of intermediate rails) of minimum dimensions 100 mm by 44 mm and of minimum density 640 kg/m<sup>3</sup>.

All doorset hardware must be CERTIFIRE approved for use with ITT doors and the leaf must be hung upon 1½ pair of hinges and incorporate a latching device and automatic closing device.

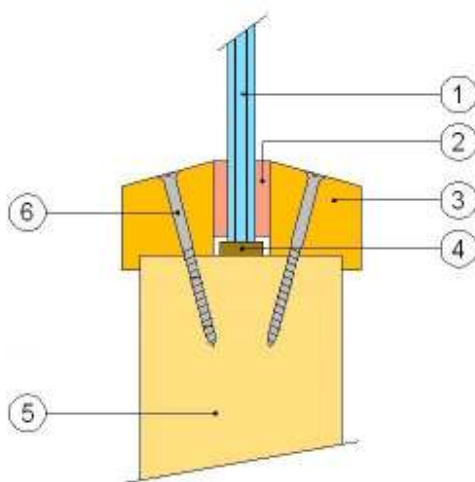

- ① Pyroguard 11 mm Glass
- ② K-Tape 15 x 3 mm
- ③ Hardwood glazing beads 35 mm by 20.5 mm including a 12 mm by 6 mm bolection return chamfered at 0-45° and minimum 650 k/m<sup>3</sup> density
- ④ Non-combustible or hardwood setting blocks
- ⑤ Door leaf as described above
- ⑥ 48 mm long steel screws at a maximum of 200mm horizontal centres and angled at 45°

**CERTIFICATE No CF 257**  
**CGI INTERNATIONAL LIMITED**

**Pyroguard 11 mm glass in timber stile and rail doorsets for periods of 30 minutes integrity (continued)**

This Certificate of Approval relates to the sizes of Pyroguard 11 mm glass shown in Figure 16 below, when used in conjunction with the glazing system detailed previously:

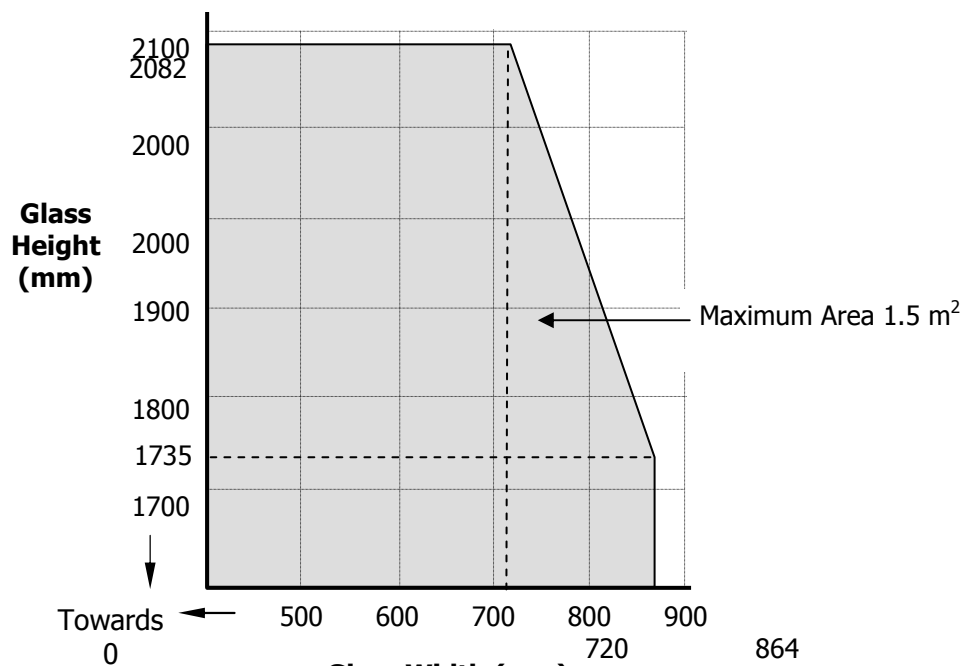

**Figure 16. Maximum Permitted Glass Dimensions**

Maximum leaf dimensions are 2382 mm high (at 920 mm wide) and 1064 mm wide (at 2035 mm high), subject to a maximum area of 2.19 m<sup>2</sup>.

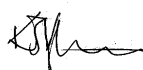

**CERTIFICATE No CF 257**  
**CGI INTERNATIONAL LIMITED**

**Pyroguard 11 mm glass (laminated or as IGUs) in single pane, horizontal steel framed screens for periods of 30 minutes integrity**

For this application the following conditions shall apply:

The glass shall be installed into a previously tested or CERTIFIRE approved framing system (which is covered appropriately by test or assessment evidence) using pressure plate glazing, screw-fixed or clip-on retaining beads, see examples below. The glass shall be glazed into the screen with CGI 'K Tape' ceramic fibre gasket on both faces. The laminated glass/IGU shall be as detailed in the table below.

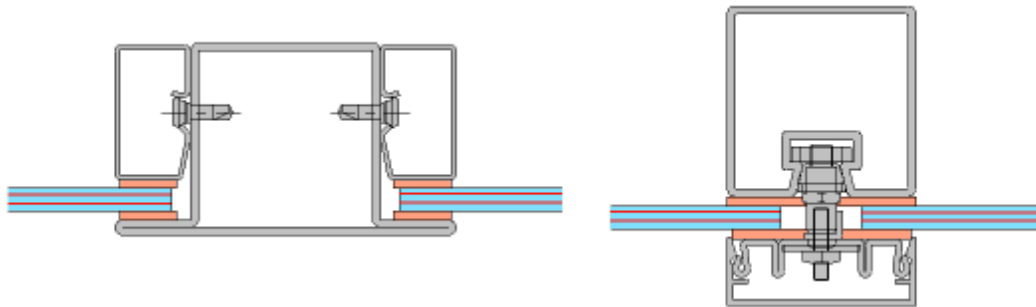

System	Construction	Orientation
1	IGU comprising 11 mm Pyroguard glass and 6 mm toughened glass	Pyroguard at the soffit
2	Laminated glass comprising 8 mm toughened glass, a 1 mm PVB layer, 11 mm Pyroguard glass, a 1 mm PVB layer and a 15 mm toughened glass	Toughened glass at the soffit
3	Laminated glass comprising 8 mm toughened glass, a 2 mm cold pour resin layer, 11 mm Pyroguard glass, a further 2 mm cold pour resin layer and 15 mm float glass	Toughened glass at the soffit

**CERTIFICATE No CF 257**  
**CGI INTERNATIONAL LIMITED**

**Pyroguard 11 mm glass (laminated or as IGUs) in single pane, horizontal steel framed screens for periods of 30 minutes integrity (continued)**

**Maximum Permitted Pane Dimensions**

This Certificate of Approval relates to the sizes of Pyroguard 11 mm Laminated/IGUs shown in Figure 17 below, when used in conjunction with the above system. The aspect ratio of the glass may be unlimited within these aperture dimensions.

